



# FFC-FLAT FLEXIBLE CABLES AXOJUMP

Designed for board-to-board interconnections in electronic systems, Axojump Flat Flexible Cables (FFC) are made up of flat tin or gold plated copper conductors insulated with Polyester or Polyimide tapes. From 0.30 mm pitch for space saving to 1.25 mm, a large variety of pitches is available to suit your needs. In addition to the standard range, Axon' has developed custom designed flat flex cables incorporating folds, shields, notches, punching, slitting or marking. Flat Flexible Cables are compatible with ZIF and LIF connectors.







## 0.30 mm pitch Flat Flexible Cables

### GENERAL CHARACTERISTICS

Temperature rating: up to 105°C.  
Voltage rating: up to 30V AC.

#### CONDUCTOR

Pitch: 0.30 mm.  
Width:  $0.20 \pm 0.015$  mm.  
Conductor thickness: 0.035 mm typical value.  
Max. conductor resistance: 2800 ( $\Omega$ /km) at 20°C.

#### CONDUCTOR PLATING

Gold: 0.3 $\mu$ m Ni (mini) / 0.05 $\mu$ m Au.

#### INSULATION

Polyester insulation with flame retardant adhesive.  
White colour.

### GENERAL DRAWING

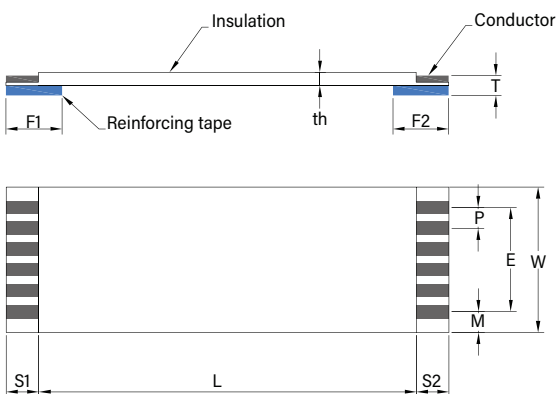

### CONNECTION SCHEME

#### WITH ZIF CONNECTORS

Reinforcement tape: Polyester L code.  
Blue colour



### PROCESSING FORMS

#### TYPE A

Reinforcements at both ends, on the same side.

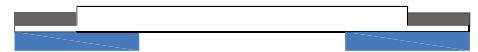

#### TYPE D

Reinforcements at both ends, on opposing side.

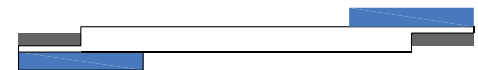

### DIMENSIONS

PITCH: P (MM)	<b>0.30 ± 0.03</b>
Number of conductors: N	11 to 51
Span: E (mm)	$(N-1) \cdot 0.30 \pm 0.03$
Width: W (mm) on connection area	$(N+1) \cdot 0.30 \pm 0.03$
Margin: M (mm)	$0.30 \pm 0.05$
Strip length: S1-S2 (mm)	$4.00 \pm 0.80$
Reinforcement length: F1-F2 (mm)	$8.00 \pm 2.00$
Insulated length: L(mm)	42 to 60 ± 2 61 to 100 ± 3 101 to 200 ± 4 201 to 500 ± 5
Thickness at end of cable: T (mm)	$0.20 \pm 0.03$
Cable thickness: th (mm)	0.12 (typical value)



0.30 MM PITCH STANDARD FLAT FLEXIBLE CABLE



## ELECTRICAL PROPERTIES

	TESTING CONDITIONS	VALUES
Dielectric Test (V AC) - Min	Conductor to conductor, during 1 mn	100
Current rating (A) - Max	FFC at 23°C - Allowable temperature rise : 40°C	0.30
Insulation resistance (MΩ.m min)	Conductor to conductor	10 at DC 100V
Continuity test	DC 3.0 V at 0.1mA	Passed
Impedance cond/cond balanced method (typical value)	FFC without shielding at 1MHz	145 Ω
Capacitance cond/cond balanced method (typical value)	FFC without shielding at 1KHz	70 pF/m



0.30 MM PITCH GOLD PLATED FLAT FLEXIBLE CABLE

## OTHER PROPERTIES

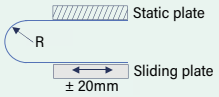
	TESTING CONDITIONS	CHARACTERISTICS	
Heat resistance	113°C, 168 hours	- Dielectric test - Insulation resistance	Passed Passed
Thermal shock	(-55°C x 30 min → 25°C x 5 min → 85°C x 30 min → 25°C x 5 min) x 25 cycles	- Dielectric test - Insulation resistance	Passed Passed
Cold coiling	-40°C, 96 hours. The sample is initially wound on a mandrel of 3 mm	At room temperature: - Visual inspection - Dielectric test - Insulation resistance	Passed Passed Passed
Wear by abrasion	Test following EN3475-503 Weight: 500 g Speed: 60 cycles/min Abrasion tool: Ø = 0.50 mm	Dielectric test Insulation resistance: - After 500 cycles	Passed
Flame resistance	UL 758	FT2 (VW-1 available on request)	
Folding	The specimen is folded manually at 180°	Continuity after more than 20 times	Passed
Moisture resistance	60°C, 95% RH, 96 hours	- Dielectric test - Insulation resistance	Passed Passed
Flex-life Number of cycles (typical values)	Speed 100 cycles /min Flex-life test is performed at 23°C 	Radius 10 mm	500 000



### IDENTIFICATION CODE

IDENTIFICATION CODE	FFC	0.30	A	25/	0200	E	4.0	4.0	08.0	08.0	E	A	LL/	AU
<b>FLAT FLEXIBLE CABLE</b>														
<b>PITCH</b> P in mm														
<b>PROCESSING FORM</b> A or D														
<b>NUMBER OF CONDUCTORS</b> N														
<b>INSULATION LENGTH</b> L in mm														
<b>INSULATION</b> E														
<b>STRIP LENGTH S1</b> in mm (4mm standard length)														
<b>STRIP LENGTH S2</b> in mm (4mm standard length)														
<b>REINFORCEMENT LENGTH F1</b> in mm (8mm standard length)														
<b>REINFORCEMENT LENGTH F2</b> in mm (8mm standard length)														
<b>CONDUCTOR THICKNESS</b> E (35 microns)														
<b>UL COMPLIANCE</b> A: No compliance														
<b>REINFORCEMENT TYPE (F1 &amp; F2)</b> L: Polyester reinforcement														
<b>OPTION</b> Plating on conductor AU: gold plating														



### 0.50, 1.00 & 1.25 mm pitch FFC - 100 $\mu$ conductors - Standard versions

## GENERAL CHARACTERISTICS

Temperature rating: up to 105°C.

Voltage rating: up to 60V AC.

### CONDUCTOR

PITCH (mm)	WIDTH (mm)	MAX CONDUCTOR RESISTANCE ( $\Omega$ km) at 20°C	CONDUCTOR THICKNESS (mm)
0.50	0.30 $\pm$ 0.02	730	0.10 $\pm$ 0.015
1.00	0.70 $\pm$ 0.03	300	0.10 $\pm$ 0.015
1.25	0.80 $\pm$ 0.03	280	0.10 $\pm$ 0.015

### CONDUCTOR PLATING

Tin: 0.4 $\mu$ m (mini)

Gold: 0.3 $\mu$ m Ni (mini) / 0.05 $\mu$ m Au.

### INSULATION

Polyester insulation with flame retardant adhesive.

White colour.

## GENERAL DRAWING

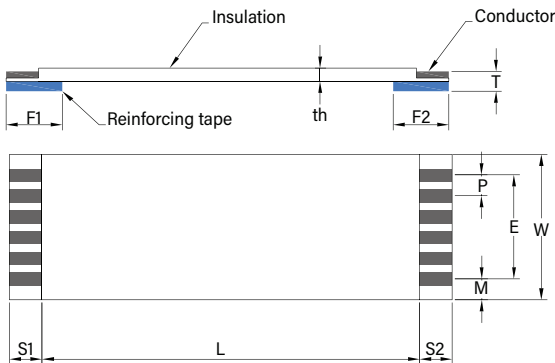

## DIMENSIONS

PITCH: P (mm)	0.50 $\pm$ 0.05	1.00 $\pm$ 0.08	1.25 $\pm$ 0.10
Number of conductors: N	6 to 80	4 to 60	4 to 60
Span: E (mm)	(N-1)*0.50 $\pm$ 0.07	(N-1)*1.00 $\pm$ 0.15	(N-1)*1.25 $\pm$ 0.15
Width: W (mm)	(N+1)*0.50 $\pm$ 0.06	(N+1)*1.00 $\pm$ 0.10	(N+1)*1.25 $\pm$ 0.15
Margin: M (mm)	0.50 $\pm$ 0.12	1.00 $\pm$ 0.20	1.25 $\pm$ 0.20
Strip length: S1-S2 (mm)	2.00 to 10.0 $\pm$ 0.80 (standard value: 4 mm)		
Reinforcement length: F1-F2 (mm)	6.00 to 20.0 $\pm$ 2.0 (standard value: 8 mm)		
Insulated length: L(mm)	20 to 60 $\pm$ 2 61 to 100 $\pm$ 3 101 to 200 $\pm$ 4	201 to 3999 $\pm$ 5 4000 to 5999 $\pm$ 10 6000 to 9999 $\pm$ 15	
Thickness at end of cable: T (mm)	0.30 $\pm$ 0.05 (only for ZIF connectors)		
Cable thickness: th (mm)	0.27 typical		

## CONNECTION SCHEME

### WITH ZIF CONNECTORS

Reinforcement tape: Polyester K code.  
Blue colour.

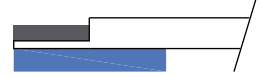

### HOT BAR SOLDERING

Reinforcement tape: Polyimide H code.  
Natural colour (amber).



### MANUAL SOLDERING

Code for the end: T  
F1 ; F2 = 2.50 mm.

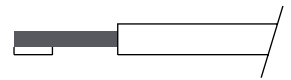

## PROCESSING FORMS

### Type A

Reinforcements at both ends,  
on the same side.

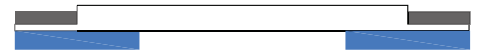

### TYPE D

Reinforcements at both ends,  
on opposing side.

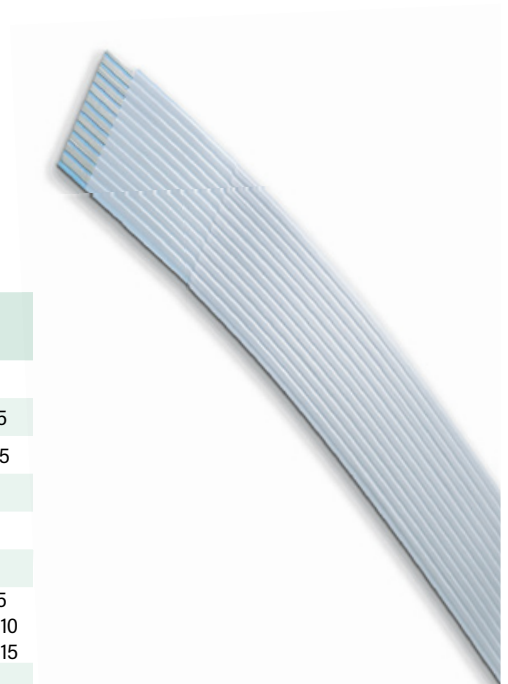
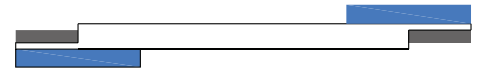

1.00 MM PITCH PLATED FLAT FLEXIBLE CABLE



## ELECTRICAL PROPERTIES

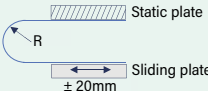

	TESTING CONDITIONS	PITCH		
		0.50	1.00	1.25
Dielectric Test (V AC) - Min	Conductor to conductor, during 1 mn	200	400	500
Current rating (A) - Max	FFC at 23°C - Allowable temperature rise : 40°C	0.55	1.25	1.40
Insulation resistance (MΩ.m min)	Conductor to conductor	10 at DC 200V	10 at DC 400V	10 at DC 500V
Continuity test	DC 3.0 V at 0.1mA	Passed	Passed	Passed
Impedance cond/cond balanced method (typical value)	FFC without shielding at 1MHz	130 Ω	120 Ω	130 Ω
Capacitance cond/cond balanced method (typical value)	FFC without shielding at 1KHz	62 pF/m	50 pF/m	30 pF/m

## OTHER PROPERTIES

	TESTING CONDITIONS	CHARACTERISTICS	
Heat resistance	136°C, 168 hours	- Dielectric test - Insulation resistance	Passed Passed
Thermal shock	(-55°C x 30 min → 25°C x 5 min → 85°C x 30 min → 25°C x 5 min) x 25 cycles	- Dielectric test - Insulation resistance	Passed Passed
Cold coiling	-40°C, 96 hours The sample is initially wound on a mandrel of 3 mm	At room temperature: - Visual inspection - Dielectric test - Insulation resistance	Passed Passed Passed
Wear by abrasion	Test following EN3475-503 Weight: 500 g Speed: 60 cycles/min Abrasion tool: Ø = 0.50 mm	Dielectric test Insulation resistance: - After 500 cycles	Passed
Flame resistance	UL 758	FT2 (VW-1 available on request)	
Folding	The specimen is folded manually at 180°	Continuity after more than 20 times	Passed
Moisture resistance	60°C, 95% RH, 96 hours	- Dielectric test - Insulation resistance	Passed Passed
Flex-life (typical values)	Speed 100 cycles /min Flex-life test is performed at 23°C 	Radius 10 mm	100 000

## SPECIAL DESIGNS

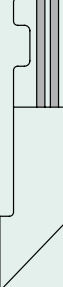
Special designs available on request, such as specific shapes for connectors with locking systems.

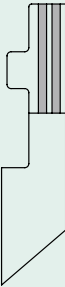
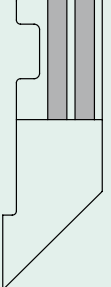
Pitch: P(mm)	0.50	0.50	0.50	0.50	1.00
FFC Drawing					



## IDENTIFICATION CODE

IDENTIFICATION CODE	FFC	1.00	A	25/	0200	S	4.0	4.0	08.0	08.0	S	A	KK/	AU
<b>FLAT FLEXIBLE CABLE</b>														
<b>PITCH</b> P in mm														
<b>PROCESSING FORM</b> A or D														
<b>NUMBER OF CONDUCTORS</b> N														
<b>INSULATION LENGTH</b> L in mm														
<b>INSULATION</b> S														
<b>STRIP LENGTH S1</b> in mm (4mm standard length)														
<b>STRIP LENGTH S2</b> in mm (4mm standard length)														
<b>REINFORCEMENT LENGTH F1</b> in mm (8mm standard length)														
<b>REINFORCEMENT LENGTH F2</b> in mm (8mm standard length)														
<b>CONDUCTOR THICKNESS</b> F: Flexible (50 microns) E: Extra flexible (35 microns)														
<b>UL COMPLIANCE</b> A: without UL marking B: UL certified 20706														
<b>REINFORCEMENT TYPE (F1 &amp; F2)</b> K: Polyester reinforcement														
<b>OPTION</b> Plating on conductor tin plating AU: gold plating														

## UL COMPLIANCE

With code A: the products are UL compliant. With code B: the products are UL certified style 20706 and shipped with UL labels. Temperature rating: 105°C; Voltage rating: 60V AC. Axon Cable UL file number: E45046. Marking definition on the cable: FFC with L > 30 mm and W > 9mm will have black printing on one side with the following text: "AXON CABLE  AWM STYLE20706 105C 60V"



## 0.50, 1.00 & 1.25 mm pitch FFC - 50-35 U conductors - Flexible & extra-flexible versions

### GENERAL CHARACTERISTICS

Temperature rating: up to 105°C.

Voltage rating: up to 60V AC.

### CONDUCTOR

PITCH (mm)	WIDTH (mm)	MAX CONDUCTOR RESISTANCE (Ω/KM) AT 20°C	
		Flexible (50 μm)	Extra flexible (35 μm)
0.50	0.30 ± 0.02	1460	2200
1.00	0.70 ± 0.03	550	790
1.25	0.80 ± 0.03	480	710
<b>Conductor thickness</b>		0.05 mm	0.035 mm

### CONDUCTOR PLATING

Tin: 0.4μm (min.)

Gold: 0.3μm Ni (min.) / 0.05μm Au.

### INSULATION

Polyester insulation with flame retardant adhesive.

White colour.

### GENERAL DRAWING

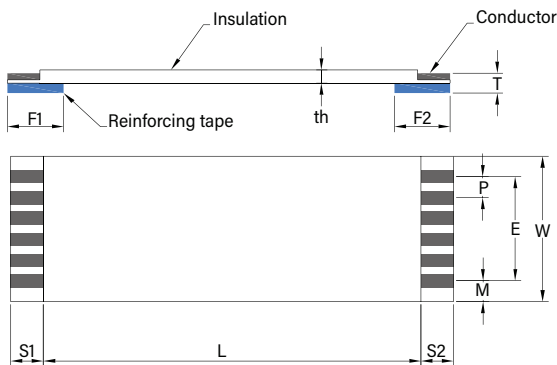

### DIMENSIONS

PITCH: P (MM)	0.50 ± 0.05	1.00 ± 0.08	1.25 ± 0.10
Number of conductors: N	6 to 80	4 to 60	4 to 60
Span: E (mm)	(N-1)*0.50 ± 0.07	(N-1)*1.00 ± 0.15	(N-1)*1.25 ± 0.15
Width: W (mm)	(N+1)*0.50 ± 0.06	(N+1)*1.00 ± 0.10	(N+1)*1.25 ± 0.15
Margin: M (mm)	0.50 ± 0.12	1.00 ± 0.20	1.25 ± 0.20
Strip length: S1-S2 (mm)	2.00 to 10.0 ± 0.80 (standard value: 4 mm)		
Reinforcement length: F1-F2 (mm)	6.00 to 20.0 ± 2.0 (standard value: 8 mm)		
Insulated length: L (mm)	20 to 60 ± 2 61 to 100 ± 3 101 to 200 ± 4		201 to 3999 ± 5 4000 to 5999 ± 10 6000 to 9999 ± 15
Thickness at end of cable: T (mm)	0.30 ± 0.05 (only for ZIF connectors)		
Cable thickness: th (mm)	Flexible: 0.14 / Extra flexible: 0.12 (typical value)		

### CONNECTION SCHEME

#### WITH ZIF CONNECTORS

Reinforcement tape: Polyester B code.  
Blue colour.

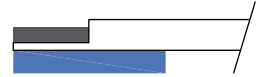

#### HOT BAR SOLDERING

Reinforcement tape: Polyimide H code.  
Natural colour (amber).



### PROCESSING FORMS

#### Type A

Reinforcements at both ends, on the same side.

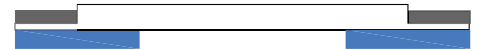

#### TYPE D

Reinforcements at both ends, on opposing side.

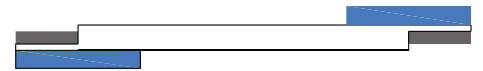

0.50 MM PITCH PUNCHED FLAT FLEXIBLE CABLE



### ELECTRICAL PROPERTIES

	TESTING CONDITIONS	PITCH		
		0.50	1.00	1.25
Dielectric Test (V AC) - Min	Conductor to conductor, during 1 mn	200	400	500
Current rating (A) - Max Flexible conductor	FFC at 23°C Allowable temperature rise: 40°C	0.40	0.80	0.85
Current rating (A) - Max Extra-flexible conductor		0.35	0.80	0.80
Insulation resistance (MΩ.m min)	Conductor to conductor	10 at DC 200V	10 at DC 400V	10 at DC 500V
Continuity test	DC 3.0 V at 0.1mA	Passed	Passed	Passed
Impedance cond/cond balanced method (typical value)	FFC without shielding at 1MHz	150 Ω	150 Ω	170 Ω
Capacitance cond/cond balanced method (typical value)	FFC without shielding at 1KHz	50 pF/m	40 pF/m	35 pF/m

### OTHER PROPERTIES

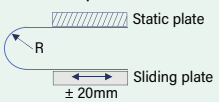
	TESTING CONDITIONS	CHARACTERISTICS		
Heat resistance	136°C, 168 hours	- Dielectric test - Insulation resistance	Passed Passed	
Thermal shock	(-55°C x 30 min → 25°C x 5 min → 85°C x 30 min → 25°C x 5 min) x 25 cycles	- Dielectric test - Insulation resistance	Passed Passed	
Cold coiling	-40°C, 96 hours The sample is initially wound on a mandrel of 3 mm	At room temperature: - Visual inspection - Dielectric test - Insulation resistance	Passed Passed Passed	
Wear by abrasion	Test following EN3475-503 Weight: 500 g Speed: 60 cycles/min Abrasion tool: Ø = 0.50 mm	Dielectric test Insulation resistance: - After 500 cycles	Passed	
Flame resistance	UL 758	FT2 (VW-1 available on request)		
Folding	The specimen is folded manually at 180°	Continuity after more than 20 times	Passed	
Moisture resistance	60°C, 95% RH, 96 hours	- Dielectric test - Insulation resistance	Passed Passed	
Flex-life Number of cycles (typical values)	Speed 100 cycles /min Flex-life test is performed at 23°C 	Raduis	5 mm	10 mm
		Flexible	300 000	2 500 000
		Extra-flexible	700 000	5 000 000

### SPECIAL DESIGNS

Special designs available on request, such as specific shapes for connectors with locking systems.

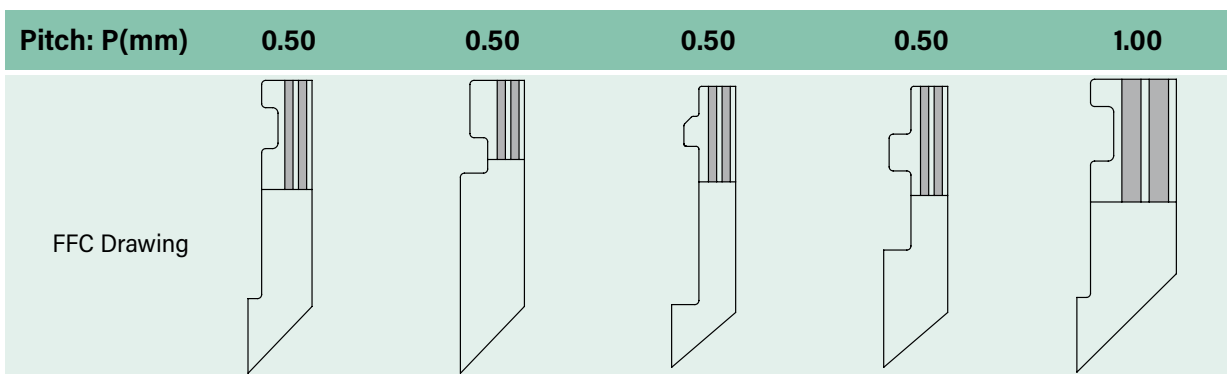



## IDENTIFICATION CODE

IDENTIFICATION CODE	FFC	1.00	A	25/	0200	E	4.0	4.0	08.0	08.0	F	A	BB/	AU
<b>FLAT FLEXIBLE CABLE</b>														
<b>PITCH</b> P in mm														
<b>PROCESSING FORM</b> A or D														
<b>NUMBER OF CONDUCTORS</b> N														
<b>INSULATION LENGTH</b> L in mm														
<b>INSULATION</b> E														
<b>STRIP LENGTH S1</b> in mm (4mm standard length)														
<b>STRIP LENGTH S2</b> in mm (4mm standard length)														
<b>REINFORCEMENT LENGTH F1</b> in mm (8mm standard length)														
<b>REINFORCEMENT LENGTH F2</b> in mm (8mm standard length)														
<b>CONDUCTOR THICKNESS</b> F: Flexible (50 microns) E: Extra flexible (35 microns)														
<b>UL COMPLIANCE</b> A: without UL marking B: UL certified 20706														
<b>REINFORCEMENT TYPE (F1 &amp; F2)</b> B: Polyester reinforcement														
<b>OPTION</b> Plating on conductor tin plating AU: gold plating														

## UL COMPLIANCE

With code A: the products are UL compliant. With code B: the products are UL certified style 20706 and shipped with UL labels. Temperature rating: 105°C; Voltage rating: 60V AC. AXON' Cable UL file number: E45046. Marking definition on the cable: FFC with L > 30 mm and W > 9mm will have black printing on one side with the following text: side with the following text: "AXON' CABLE  AWM STYLE20706 105C 60V"



### 1.00 mm pitch FFC - 25 U conductors - Ultra-flexible versions

## GENERAL CHARACTERISTICS

Temperature rating: up to 105°C.

Voltage rating: up to 60V AC.

### CONDUCTOR

PITCH (mm)	WIDTH (MM)	MAX CONDUCTOR RESISTANCE (Ω/km) at 20°C
		Ultra flexible (25 μm)
1.00	0.60 ± 0.03	1500
CONDUCTOR THICKNESS		0.025 MM

### CONDUCTOR PLATING

Tin: 0.4μm (min.)

Gold: 0.3μm Ni (min.) / 0.05μm Au.

### INSULATION

Polyester insulation with flame retardant adhesive.

White colour.

## GENERAL DRAWING

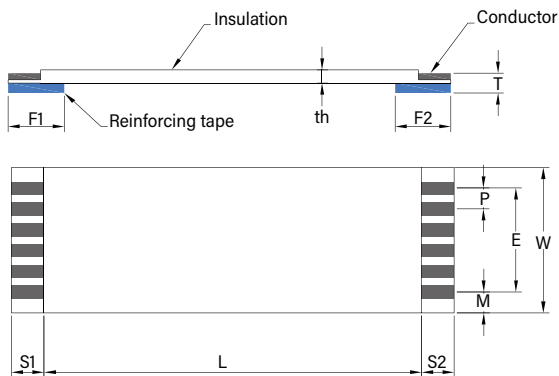

## DIMENSIONS

<b>PITCH: P (mm)</b>	<b>1.00 mm PITCH ± 0.08</b>	
<b>Number of conductors: N</b>	4 to 60	
<b>Span: E (mm)</b>	(N-1)*0.50 ± 0.15	
<b>Width: W (mm)</b>	(N+1)*0.50 ± 0.10	
<b>Margin: M (mm)</b>	1.00 ± 0.20	
<b>Strip length: S1-S2 (mm)</b>	2.00 to 10.0 ± 0.80 (standard value: 4 mm)	
<b>Reinforcement length: F1-F2 (mm)</b>	6.00 to 20.0 ± 2.0 (standard value: 8 mm)	
<b>Insulated length: L(mm)</b>	20 to 60 ± 2	201 to 3999 ± 5
	61 to 100 ± 3	4000 to 5999 ± 10
	101 to 200 ± 4	6000 to 9999 ± 15
<b>Thickness at end of cable: T (mm)</b>	0.30 ± 0.05 (only for ZIF connectors)	
<b>Cable thickness: th (mm)</b>	0.11 (typical value)	

## CONNECTION SCHEME

### WITH ZIF CONNECTORS

Reinforcement tape: Polyester B code.

Blue colour.



## PROCESSING FORMS

### Type A

Reinforcements at both ends, on the same side.

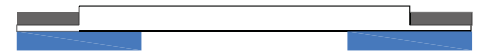

### TYPE D

Reinforcements at both ends, on opposing side.

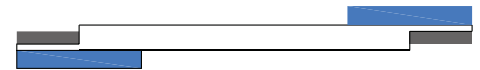

ULTRA-FLEXIBLE FLAT CABLE



## ELECTRICAL PROPERTIES

	TESTING CONDITIONS	1.00 mm PITCH
Dielectric Test (V AC) - Min	In air, during 1 mn	400
Current rating (A) - Max Extra-flexible conductor	FFC at 23°C Allowable temperature rise: 40°C	0.50
Insulation resistance (MΩ.m min)	Conductor to conductor	10 at DC 400V
Continuity test	DC 3.0 V at 0.1mA	Passed
Impedance cond/cond balanced method (typical value)	FFC without shielding at 1MHz	90 Ω
Capacitance cond/cond balanced method (typical value)	FFC without shielding at 1KHz	30 pF/m

## OTHER PROPERTIES

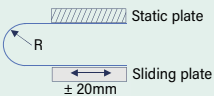
	TESTING CONDITIONS	CHARACTERISTICS		
Heat resistance	136°C, 168 hours	- Dielectric test - Insulation resistance	Passed Passed	
Thermal shock	(-55°C x 30 min → 25°C x 5 min → 85°C x 30 min → 25°C x 5 min) x 25 cycles	- Dielectric test - Insulation resistance	Passed Passed	
Cold coiling	-40°C, 96 hours The sample is initially wound on a mandrel of 3 mm	At room temperature: - Visual inspection - Dielectric test - Insulation resistance	Passed Passed Passed	
Wear by abrasion	Test following EN3475-503 Weight: 500 g Speed: 60 cycles/min Abrasion tool: Ø = 0.50 mm	Dielectric test Insulation resistance: - After 500 cycles	Passed	
Flame resistance	UL 758	FT2 (VW-1 available on request)		
Folding	The specimen is folded manually at 180°	Continuity after more than 20 times	Passed	
Moisture resistance	60°C, 95% RH, 96 hours	- Dielectric test - Insulation resistance	Passed Passed	
Flex-life Number of cycles (typical values)	Speed 100 cycles /min Flex-life test is performed at 23°C 	Raduis	5 mm	10 mm
		Ultra-flexible	10 000 000	70 000 000



FLEX LIFE TEST

## UL COMPLIANCE

With code A: the products are UL compliant.  
With code B: the products are UL certified style 20706 and shipped with UL labels.

Temperature rating: 105°C; Voltage rating: 60V AC.

Axon'Cable UL file number: E45046.

Marking definition on the cable:

FFC with L > 30 mm and W > 9mm will have black printing on one side with the following text:  
"AXON'CABLE  AWM STYLE20706 105C 60V"



## IDENTIFICATION CODE

IDENTIFICATION CODE	FFC	1.00	A	25/	0200	E	4.0	4.0	08.0	08.0	U	A	BB/	AU
<b>FLAT FLEXIBLE CABLE</b>														
<b>PITCH</b> P in mm														
<b>PROCESSING FORM</b> A or D														
<b>NUMBER OF CONDUCTORS</b> N														
<b>INSULATION LENGTH</b> L in mm														
<b>INSULATION</b> E														
<b>STRIP LENGTH S1</b> in mm (4mm standard length)														
<b>STRIP LENGTH S2</b> in mm (4mm standard length)														
<b>REINFORCEMENT LENGTH F1</b> in mm (8mm standard length)														
<b>REINFORCEMENT LENGTH F2</b> in mm (8mm standard length)														
<b>CONDUCTOR THICKNESS</b> U: Ultra Flexible (25 microns)														
<b>UL COMPLIANCE</b> A: without UL marking B: UL certified 20706														
<b>REINFORCEMENT TYPE (F1 &amp; F2)</b> B: Polyester reinforcement														
<b>OPTION</b> Plating on conductor tin plating AU: gold plating														



## Shielded flat flexible cables

### GENERAL CHARACTERISTICS

Temperature rating: up to 105°C.  
Voltage rating: up to 60V AC.

#### CONDUCTOR

PITCH (mm)	WIDTH (mm)	MAX CONDUCTOR RESISTANCE (Ω/km) at 20°C
0.50	0.30 ± 0.02	1460
1.00	0.70 ± 0.03	550
Conductor thickness		0.05 mm

#### CONDUCTOR PLATING

Tin: 0.4µm (min.)  
Gold: 0.3µm Ni (min.) / 0.05µm Au.

#### INSULATION

Polyester insulation with flame retardant adhesive.  
White colour.

#### SHIELDING

Aluminium tape with Polyester insulation  
Grey colour

Shielding is possible on flat cables with:  
- a width W of 5 to 40 mm and a length L of 70 to 300 mm,  
- For other dimensions (Please contact us for further information).

### GENERAL DRAWING

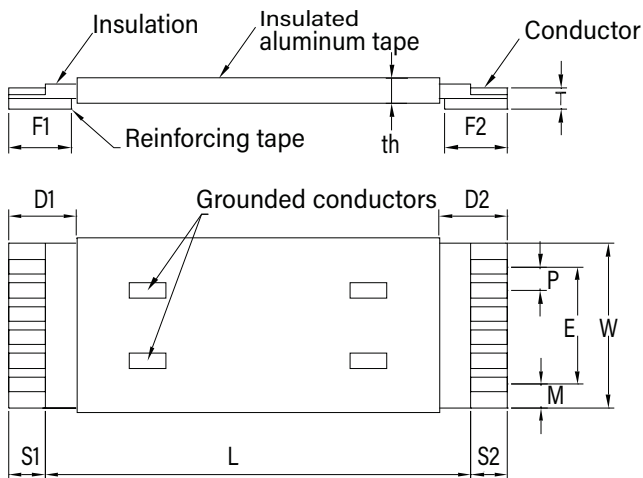

### CONNECTION SCHEME

#### WITH ZIF CONNECTORS

Reinforcement tape: Polyester B or J code. Blue colour.



### PROCESSING FORMS

#### Type A

Reinforcements at both ends, on the same side.

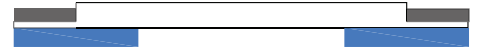

#### TYPE D

Reinforcements at both ends, on opposing side.

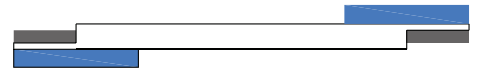

- Version S  
Aluminium shielded version without grounding.
- Version G + grounded tracks (for example G2-5)  
Aluminium shielded version with grounding (no limit for the number of grounds).

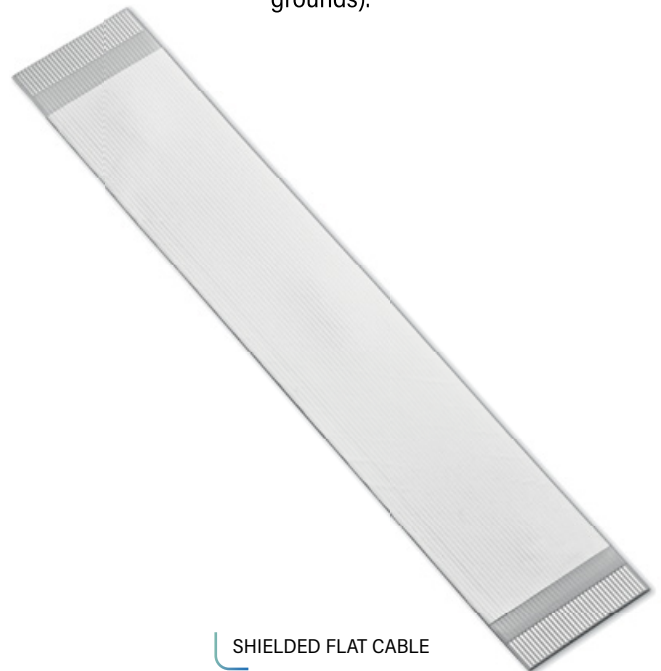

SHIELDED FLAT CABLE



## DIMENSIONS

<b>PITCH: P (mm)</b>	<b>0.50 ± 0.05</b>	<b>1.00 ± 0.08</b>
<b>Number of conductors: N</b>	9 to 79	4 to 39
<b>Span: E (mm)</b>	(N-1)*0.50 ± 0.07	(N-1)*1.00 ± 0.15
<b>Width: W (mm)</b>	(N+1)*0.50 ± 0.10	(N+1)*1.00 ± 0.10
<b>Margin: M (mm)</b>	0.50 ± 0.12	1.00 ± 0.20
<b>Strip length: S1-S2 (mm)</b>	2.00 to 10.0 ± 0.80 (standard value: 4 mm)	
<b>Reinforcement length: F1-F2 (mm)</b>	6.00 to 20.0 ± 2.0 (standard value: 8 mm)	
<b>Shielding position: D1-D2 (mm)</b>	(F1 or F2 max + 1) ± 3	
<b>Insulated length: L(mm)</b>	70 to 100 ± 3 101 to 200 ± 4 201 to 300 ± 5	
<b>Thickness at end of cable: T (mm)</b>	0.30 ± 0.05	
<b>Cable thickness: th (mm)</b>	0.20 (typical value)	0.26 (typical value)

## ELECTRICAL PROPERTIES

	TESTING CONDITIONS	PITCH	
		0.50 mm	1.00 mm
<b>Dielectric Test (V AC) - Min</b>	Conductor to conductor, during 1 mn	200	400
<b>Current rating (A) - Max at 23°C</b> <b>Allowable temperature rise: 40°C</b>	Flexible conductor	0.50	1.00
<b>Insulation resistance (MΩ.m min)</b>	Conductor to conductor	10 at DC 200V	10 at DC 400V
<b>Continuity test</b>	DC 3.0 V at 0.1mA	Passed	Passed
<b>Impedance cond/cond balanced method (typical value)</b>	FFC with shielding at 1MHz	67 Ω	60 Ω
<b>Impedance cond/shielding (typical value)</b>	FFC with shielding at 1MHz	45 Ω	40 Ω
<b>Capacitance cond/cond balanced method (typical value)</b>	FFC with shielding at 1KHz	230 pF/m	220 pF/m
<b>Capacitance cond/shielding (typical value)</b>	FFC with shielding at 1KHz	470 pF/m	500 pF/m

## OTHER PROPERTIES

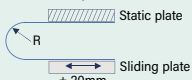
	TESTING CONDITIONS	CHARACTERISTICS	
<b>Heat resistance</b>	136°C, 168 hours	- Dielectric test - Insulation resistance	Passed Passed
<b>Thermal shock</b>	(-55°C x 30 min → 25°C x 5 min → 85°C x 30 min → 25°C x 5 min) x 25 cycles	- Dielectric test - Insulation resistance	Passed Passed
<b>Cold coiling</b>	-40°C, 96 hours The sample is initially wound on a mandrel of 3 mm	At room temperature: - Visual inspection - Dielectric test - Insulation resistance	Passed Passed Passed
<b>Wear by abrasion</b>	Test following EN3475-503 Weight: 500 g Speed: 60 cycles/min Abrasion tool: Ø = 0.50 mm	Dielectric test Insulation resistance: - After 500 cycles	Passed
<b>Flame resistance</b>	UL 758	FT2 (VW-1 available on request)	
<b>Folding</b>	The specimen is folded manually at 180°	Continuity after more than 20 times	Passed
<b>Moisture resistance</b>	60°C, 95% RH, 96 hours	- Dielectric test - Insulation resistance	Passed Passed
<b>Flex-life</b> Number of cycles (typical values)	Speed 100 cycles /min Flex-life test is performed at 23°C 	Raduis 10 mm	1 000 000 cycles



## IDENTIFICATION CODE

IDENTIFICATION CODE	FFC	1.00	A	25/	0200	B	4.0	4.0	08.0	08.0	F	A	JJ/	AU	G2-5
<b>FLAT FLEXIBLE CABLE</b>															
<b>PITCH</b> P in mm															
<b>PROCESSING FORM</b> A or D															
<b>NUMBER OF CONDUCTORS</b> N															
<b>INSULATION LENGTH</b> L in mm															
<b>INSULATION</b> E (for pitch of 0.5 mm) B (for pitch of 1.0 mm)															
<b>STRIP LENGTH S1</b> in mm (4mm standard length)															
<b>STRIP LENGTH S2</b> in mm (4mm standard length)															
<b>REINFORCEMENT LENGTH F1</b> in mm (8mm standard length)															
<b>REINFORCEMENT LENGTH F2</b> in mm (8mm standard length)															
<b>CONDUCTOR THICKNESS</b> F: Flexible (50 microns)															
<b>UL COMPLIANCE</b> A: without UL marking B: UL certified 20706															
<b>REINFORCEMENT TYPE (F1 &amp; F2)</b> JJ (for pitch of 0.5 mm) J (for pitch of 1 mm)															
<b>OPTION</b> Plating on conductor tin plating AU: gold plating															
<b>SHIELDING</b> S: Aluminium shielding without grounding G: Grounded Aluminium shielding + n° of grounded conductors															

## UL COMPLIANCE

UL compliance only for shielded FFC without grounding. With code A: the products are UL compliant. With code B: the products are UL certified style 20706 and shipped with UL labels. Temperature rating: 105°C; Voltage rating: 60V AC. AXON' Cable UL file number: E45046. Marking definition on the cable: FFC with L > 30 mm and W > 9mm will have black printing on one side with the following text: "AXON' CABLE  AWM STYLE20706 105C 60V"