

AXON' CABLE SA

✉ BP1 : ROUTE DE CHALONS-EN-CHAMPAGNE
51210 MONTMIRAIL – France

☎ : (+33) 03 26 81 70 00 - FAX : (+33) 03 26 81 28 83

Web: <http://www.axon-cable.com>

Aerospace series

Contact, electrical, triaxial, socket, size 8K6

RECORD OF REVISIONS

Issue	Clause modified	Description of modification
A August 2010	Not applicable	Creation of product line
B September 2011	§3	Update according to the issue B of P547176 plan: addition of the identification code and details of rear ferules design
C February 2017	None	Update according to the "09074-DF-ACB7-A01-22" definition file: pusher evolution to secure wiring of contact

1) Scope

This specification gives the dimensions, the mass and the main characteristics of an electrical contact, triaxial, size 8, socket and crimp type.

This contact is to be installed into size 8 cavities of ABS1340, ABS1343, ABS1426, ABS1427, EN2997 and EN3545 connectors. It is compatible with cables listed in table 5.

Half mated part is defined in ACB7-P-TS-01 technical specification.

2) Applicable and reference documents

ABS1340	Aerospace series – Connector, electrical, circular, plug, with backshell, coupled by threaded ring, operating temperature +200 °C continuous, +260 °C peak.
ABS1343	Aerospace series - Connectors, electrical, circular, plug, with backshell, coupled by threaded ring, operating temperature +175 °C continuous.
ABS1426	Aerospace series – Connector, electrical, circular, receptacle, with backshell, coupled by threaded ring, operating temperature +175 °C continuous.
ABS1427	Aerospace series – Connector, electrical, circular, receptacle, with backshell, coupled by threaded ring, operating temperature +200 °C continuous, +260 °C peak.
ADB100.1.6	Airbus-Equipment-Design-General requirements for suppliers (Product – Material)
EN2997-001	Aerospace series – Connectors, electrical, circular, coupled by threaded ring. Part 001: Technical specification.
EN3545-001	Aerospace series - Connectors, electrical, rectangular, with sealed and non-sealed rear, plastic housing, locking device, operating temperatures -55 °C to +175 °C – Part 001: Technical specification.
EN2591	Elements of electrical and optical connection - Test methods
EN3155-01	Electrical contacts used in elements of connection - Part 001: Technical specification
EN3375-04	Aerospace series – Cable, electrical for digital data transmission. Part 004: Double braid – 77 Ohms – Type WJ – Product standard.
EN3375-06	Aerospace series - Cable, electrical, for digital data transmission - Part 006: Single braid – 78 Ohms – Type XM – Product standard.
EN3909	Aerospace series. Test fluids and test methods for electric components and sub-assemblies
EN4008-003	Aerospace series – Elements of electrical and optical connection – Crimping tools and associated accessories – Part 003: Positionner for crimping tool M22520/7-01 for EN3155-020 and EN3155-021 – Product standard.
IEC96.4	Test method for transfer impedance measurement
M81969/14	Installing and removal tools, connector electrical contact, type III, class 2, composition B.
MIL-C-22520/2	Crimping tools terminal, hand, wire, termination for wire barrel sizes 20 through 28.
MIL-C-22520/5	Crimping tools terminal, hand, wire, termination, large for coaxial, shielded contacts and ferrules, terminal lugs, splices and end caps.
ACB7-P-TS-01	Aerospace series - Contact, electrical, triaxial, pin, size 8K6
CON-1553-GF66	Assembly instruction for ACB6 and ACB7 contacts

3) Characteristics

3.1) Configuration, dimensions, tolerances and mass

The configuration, dimensions and tolerances shall be in accordance with figures 1 and 2.

Mass of the contact: 5.5 g max.

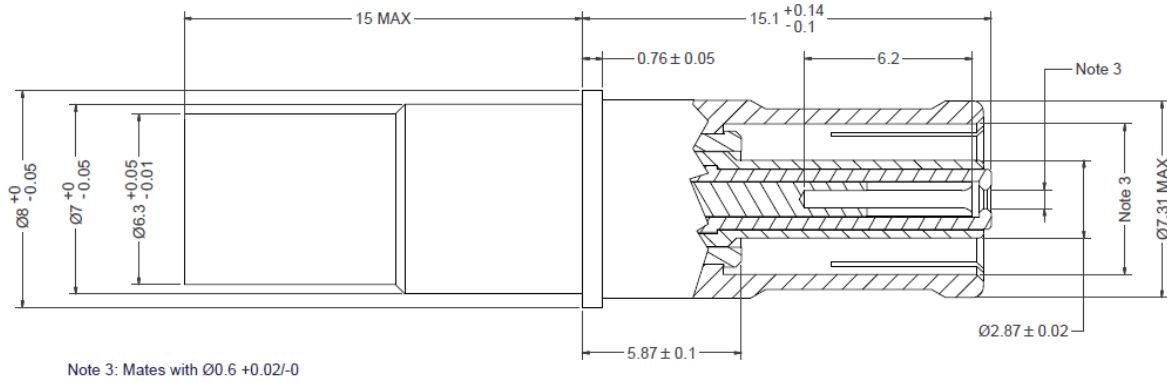

Dimensions in millimeter after surface treatment (when applicable)

Figure 1: Configuration, dimensions and tolerances of socket contact

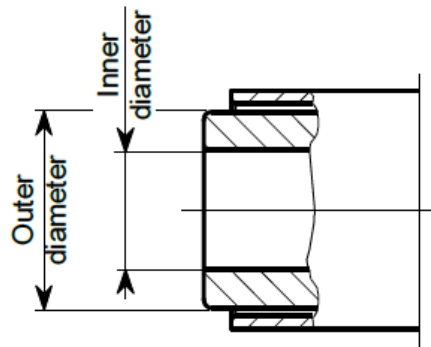

Figure 2: Configuration and tolerances of rear ferule

Table 1 defines the rear ferule in function of cable type to be used

Ferule code	Engraving	Cable compatibility	Outer diameter (mm)	Inner diameter (mm)
A	One groove centred	EN3375-006 (XM24)	5.21	3.17
C	Three grooves centred	EN3375-004 (WJ24)	4.85	3.96

Table 1: Ferule designation and dimensions

3.2) Material and surface treatment

Material and surface treatment are defined in table 2.

Elements	Material	Surface treatment
Outer body	Copper alloy	Gold plating with thickness $\geq 1.27 \mu\text{m}$
Center contact	Copper alloy	
Intermediate contact	Copper alloy	
Crimp ferrule	Copper alloy	
Insulation parts	PEEK (Polyetheretherketone)	Without

Table 2: Material and surface treatment

3.3) General characteristics

General characteristic of contacts are given in the table 3.

Description	Characteristic
Operating temperature range	-65°C to +200°C
Salt spray	48 hours
Durability (Mounting / Dismounting)	500 cycles

Table 3: General characteristics

3.4) Electrical characteristics

Electrical characteristic of the contact are given in the table 4.

Description	Characteristic	
Insulation resistance (500 V _{DC} voltage)	5 000 M Ω min. at +20°C	
Center contact resistance (initial state)	15 m Ω max. at +20°C	
Intermediate contact resistance (initial state)	15 m Ω max. at +20°C	
Outer contact resistance (initial state)	3 m Ω max. at +20°C	
Voltage strength	Center / Intermediate (sea level)	1 000 V _{RMS}
	Intermediate / Outer (sea level)	500 V _{RMS}
	21 000 m	125 V _{RMS}

Table 4: Electrical characteristics

3.5) Admissible cables

Admissible cables and rear ferule necessary to match with are specified in table 5:

Cable type	Rear ferule code
EN3375-006 (XM24)	A
EN3375-004 (WJ24)	C

Table 5: Admissible cable and ferule type

3.6) Qualification tests

Qualification test program applied to the contacts is based on EN3155-001 standard which refer to EN2591 test methods. Deviations with these documents were applied when needed to take into account product specificity (e.g. feature of connectors to be used with).

Table 6 gives the list of the test performed and details the requirement when needed.

Test method	Test	Applicability and requirement																			
		According to EN3155-001	Remarks																		
EN2591-101	Visual examination	Yes																			
EN2591-102	Examination of dimensions and mass	Yes																			
EN2591-201	Contact resistance – Low level	Yes	<table border="1"> <thead> <tr> <th rowspan="2">Contact</th> <th rowspan="2">Current (mA)</th> <th colspan="2">Maximum contact resistance (mΩ)</th> </tr> <tr> <th>Initial</th> <th>After tests</th> </tr> </thead> <tbody> <tr> <td>Center</td> <td>10</td> <td>15</td> <td>30</td> </tr> <tr> <td>Intermediate</td> <td>10</td> <td>15</td> <td>30</td> </tr> </tbody> </table>	Contact	Current (mA)	Maximum contact resistance (mΩ)		Initial	After tests	Center	10	15	30	Intermediate	10	15	30				
Contact	Current (mA)	Maximum contact resistance (mΩ)																			
		Initial	After tests																		
Center	10	15	30																		
Intermediate	10	15	30																		
EN2591-202	Contact resistance – at rated current	Yes	<table border="1"> <thead> <tr> <th rowspan="2">Contact</th> <th rowspan="2">Rated current (A)</th> <th colspan="2">Maximum contact resistance (mΩ)</th> </tr> <tr> <th>Initial</th> <th>After tests</th> </tr> </thead> <tbody> <tr> <td>Center</td> <td>1</td> <td>15</td> <td>30</td> </tr> <tr> <td>Intermediate</td> <td>1</td> <td>15</td> <td>30</td> </tr> <tr> <td>Outer body</td> <td>12</td> <td>3.0</td> <td>4.0</td> </tr> </tbody> </table>	Contact	Rated current (A)	Maximum contact resistance (mΩ)		Initial	After tests	Center	1	15	30	Intermediate	1	15	30	Outer body	12	3.0	4.0
Contact	Rated current (A)	Maximum contact resistance (mΩ)																			
		Initial	After tests																		
Center	1	15	30																		
Intermediate	1	15	30																		
Outer body	12	3.0	4.0																		
EN2591-206	Measurement of insulation resistance	Yes	<table border="1"> <thead> <tr> <th>Test configuration</th> <th>Test voltage</th> <th>Insulation @ 25°C</th> <th>Insulation at +200°C</th> </tr> </thead> <tbody> <tr> <td>Center / inter. contacts</td> <td>500 V_{DC}</td> <td>≥ 5 GΩ</td> <td>≥ 2 GΩ</td> </tr> <tr> <td>Inner contacts / outer body</td> <td>500 V_{DC}</td> <td>≥ 5 GΩ</td> <td>≥ 2 GΩ</td> </tr> </tbody> </table>	Test configuration	Test voltage	Insulation @ 25°C	Insulation at +200°C	Center / inter. contacts	500 V _{DC}	≥ 5 GΩ	≥ 2 GΩ	Inner contacts / outer body	500 V _{DC}	≥ 5 GΩ	≥ 2 GΩ						
Test configuration	Test voltage	Insulation @ 25°C	Insulation at +200°C																		
Center / inter. contacts	500 V _{DC}	≥ 5 GΩ	≥ 2 GΩ																		
Inner contacts / outer body	500 V _{DC}	≥ 5 GΩ	≥ 2 GΩ																		
EN2591-207	Voltage proof test	Yes	<table border="1"> <thead> <tr> <th>Test configuration (sea level)</th> <th>Test voltage</th> <th>Leakage current</th> </tr> </thead> <tbody> <tr> <td>Center / inter. contacts</td> <td>1000 V_{RMS}</td> <td>≤ 5 mA</td> </tr> <tr> <td>Inner contacts / outer body</td> <td>500 V_{RMS}</td> <td>≤ 5 mA</td> </tr> </tbody> </table>	Test configuration (sea level)	Test voltage	Leakage current	Center / inter. contacts	1000 V _{RMS}	≤ 5 mA	Inner contacts / outer body	500 V _{RMS}	≤ 5 mA									
Test configuration (sea level)	Test voltage	Leakage current																			
Center / inter. contacts	1000 V _{RMS}	≤ 5 mA																			
Inner contacts / outer body	500 V _{RMS}	≤ 5 mA																			
IEC96.4	Surface transfer Impedance	No	A comparative method based on the IEC96.4 standard was preferred to the EN2591-212 procedure																		
EN2591-301	Endurance at temperature	Yes	Temperature maximum: 200°C / 1000 H																		
EN2591-305	Rapid change of temperature	Yes	Ta= +200 ^{±2} °C Tb= -65 ^{±2} °C Dwell time: 30 minutes																		
EN2591-306	Mould growth	Yes	Method A – 28 days																		
EN2591-307	Salt mist	Yes	96 hours - No corrosion allowed																		

Test method	Test	Applicability and requirement																																	
		According to EN3155-001	Remarks																																
EN3909	Fluid resistance	No	List of applicable fluids was extracted from ADB100.1.6																																
EN2591-402	Shock	Yes	<p>Contacts are inserted in test connectors</p> <p><u>Method A (half sine pulse):</u></p> <ul style="list-style-type: none"> ▪ Severity: 300 ▪ Acceleration: 30 g ▪ Pulse duration: 3 ms ▪ Number of shocks: three in each way for each of the three directions (18 in total) <p><i>Note: contacts are inserted in test connectors to complete the vibration sequence</i></p>																																
EN2591-403	Sinusoidal and random vibration	Yes	<p><u>Method A (sine):</u></p> <ul style="list-style-type: none"> ▪ Frequency range: 5Hz to 3000 Hz ▪ Acceleration: 20 g ▪ Sweep rate: 1 octave per minute ▪ Amplitude: 1 mm ▪ Duration: 4 hours per axis (12 hours in total) <p><i>Note: sine vibration were added to demonstrate withstanding of contacts with requirements of EN3545-01 standard</i></p> <p><u>Method B (random):</u></p> <ul style="list-style-type: none"> ▪ Vibration levels: Figure 3 , Table 2, level J ▪ Duration: : 8 h in the longitudinal axis & 8 h in a perpendicular direction to the longitudinal axis (16 hours in total) <p><i>Note: contacts are inserted in test connectors to complete the vibration sequence</i></p>																																
524.5071-05-issue 3	Wind milling	No	<p><u>Method: 524.5071-05</u></p> <ul style="list-style-type: none"> ▪ Vibration levels: Figure 2, table 2, level J ▪ Duration: 3 hours per axis (9 hours in total) <p><i>Note: contacts are inserted in test connectors to complete the vibration sequence</i></p>																																
EN2591-406	Mechanical endurance	Yes	500 cycles																																
EN2591-418	Gauge insert and extraction forces in and out of a female contact	Yes	<table border="1" style="width: 100%; border-collapse: collapse;"> <thead> <tr> <th colspan="4" style="text-align: center;">Center contact</th> </tr> <tr> <th colspan="2" style="text-align: center;">Initial</th> <th colspan="2" style="text-align: center;">After test</th> </tr> <tr> <th style="text-align: center;">Insertion max.</th> <th style="text-align: center;">Extraction min.</th> <th style="text-align: center;">Insertion max.</th> <th style="text-align: center;">Extraction min.</th> </tr> </thead> <tbody> <tr> <td style="text-align: center;">3.36 N</td> <td style="text-align: center;">0.14 N</td> <td style="text-align: center;">3.59 N</td> <td style="text-align: center;">0.11 N</td> </tr> </tbody> </table> <table border="1" style="width: 100%; border-collapse: collapse;"> <thead> <tr> <th colspan="4" style="text-align: center;">Outer contact</th> </tr> <tr> <th colspan="2" style="text-align: center;">Initial</th> <th colspan="2" style="text-align: center;">After test</th> </tr> <tr> <th style="text-align: center;">Insertion max.</th> <th style="text-align: center;">Extraction min.</th> <th style="text-align: center;">Insertion max.</th> <th style="text-align: center;">Extraction min.</th> </tr> </thead> <tbody> <tr> <td style="text-align: center;">13.35 N</td> <td style="text-align: center;">0.83 N</td> <td style="text-align: center;">16.68 N</td> <td style="text-align: center;">0.55 N</td> </tr> </tbody> </table>	Center contact				Initial		After test		Insertion max.	Extraction min.	Insertion max.	Extraction min.	3.36 N	0.14 N	3.59 N	0.11 N	Outer contact				Initial		After test		Insertion max.	Extraction min.	Insertion max.	Extraction min.	13.35 N	0.83 N	16.68 N	0.55 N
Center contact																																			
Initial		After test																																	
Insertion max.	Extraction min.	Insertion max.	Extraction min.																																
3.36 N	0.14 N	3.59 N	0.11 N																																
Outer contact																																			
Initial		After test																																	
Insertion max.	Extraction min.	Insertion max.	Extraction min.																																
13.35 N	0.83 N	16.68 N	0.55 N																																

Table 6: qualification tests

3.6) Wiring

3.6.1) Crimping tools

The tools and selector positions recommended are indicated in table 7.

Part	Crimping tool	Positionner / dies location
Center contact	M22520/2-01	K1616SP (DMC)
Intermediate contact	M22520/5-01	EN4008-003 - punch
Outer body	M22520/5-01	EN4008-003 - hexagon

Table 7: crimping tools

3.6.2) Insertion / extraction tools

Insertion and extraction of contact from the connector has to be done with MIL-I-81969/14-06 tool type.

3.6.3) Assembly instruction

Contact has to be wired according to the last issue of “CON-1553-GF-66” AXON’ procedure

4) Commercial identification code:

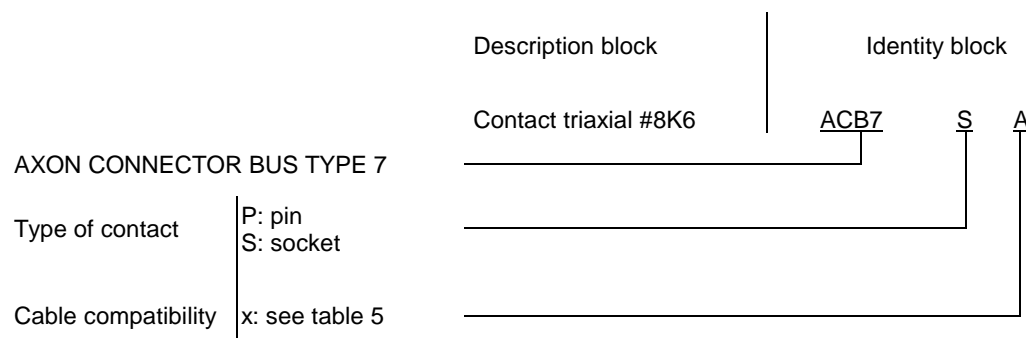

5) Marking:

Contact body is identified with a monogram specific to Axon’ company.

The contacts are packaged and identified individually.

Packaging labeling includes:

- Axon’ name
- Axon’ commercial designation
- Axon’ part number
- The manufacturing date code (year / week)